

REMOVAL AND REPAIR INSTRUCTIONS **GR 65÷80 R**

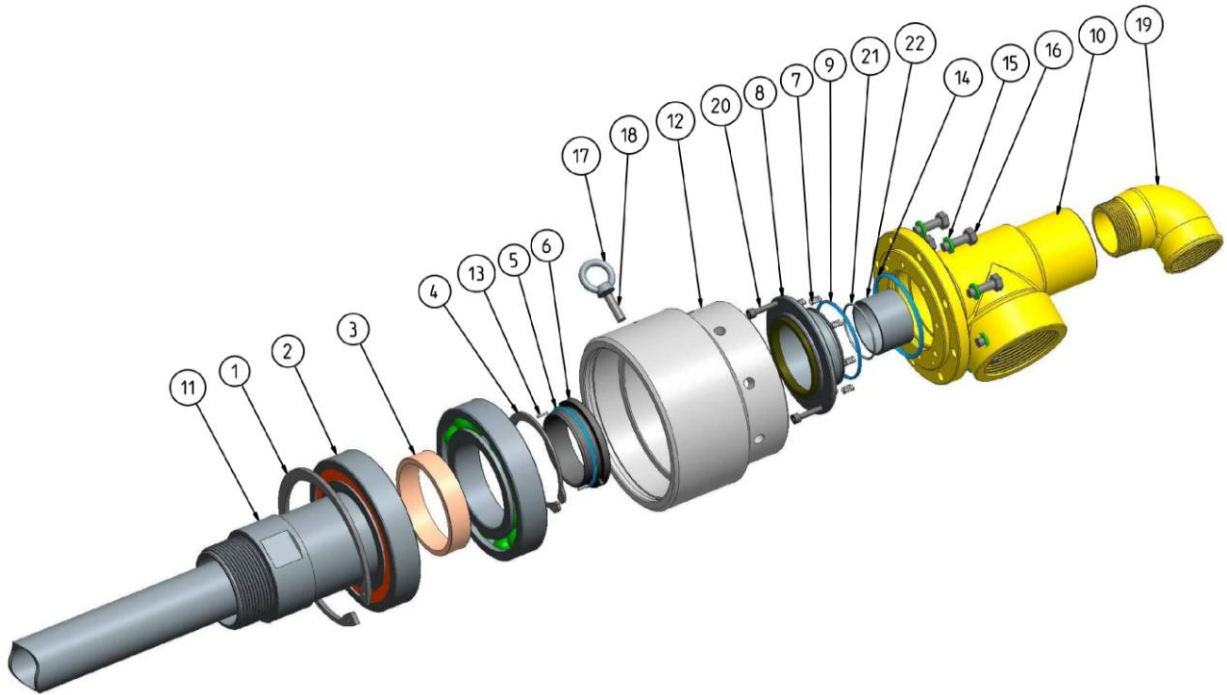

Before working on the rotary joints make sure to follow the security procedures imposed by current regulations. Read the instructions carefully before performing maintenance. Refer to the assembly drawings and / or consult Turian company or one of its authorized distributors. Make sure that the circuit is not pressurized and discharge any residual pressure. Wait until joint is cool. Use appropriate gloves.

ORDINARY MAINTENANCE

Do lubrication periodically as attached **table 1** with relative quantity of grease OKS 432 or compatible as indicated in the **table 2** only for rotary joints with greaser. Perform daily a visual check of eventual leakage that may occur from the connections, if any, stop the operation of the machine and eliminate leakage; if the rotary joint leak, replace with a new one and proceed as follow for repairment after having required seal kit and a pair of bearings.

REMOVAL AND REPLACEMENT OF BEARINGS AND SEALS

REMOVAL

Remember to use latex gloves when handling components lubricated.

- First remove screws **16** and separate body **10** from ball bearings housing **12**
- Remove the two screws **20**, the static seal **8**, springs **7** and O-Ring **14**
- Remove, if needed, the circlip **21** and bushing **22** (not included in standard kit, it has to be ordered separately)
- Check ball bearings, if they are not damaged You can replace only the rotating face seal **6** with O-Ring **5**
- If ball bearings have to be replaced
- Remove the snap ring **1** from bearings housing **12**
- Remove rotor **11** with bearings **12** using appropriate tools (education available on request)

- Remove the snap ring **4** and slide bearings **2** with relative spacer **3**
- Thoroughly clean and dry body **2**, rotor **1** and bearings housing **12**

REPLACEMENT

- Mount the (new) bushing **22** and circlip **21**
- Check that the O-Ring **9** in the body **10** seat is smooth and without damage (cylindrical section positioned between radial entry and home anti-rotation screws **20**)
- Lubricate with silicone grease housing hole of the stationary seal **8** in the body **10** and O-Rings **9** and **14**
- Insert in the holes the springs **7**
- Insert the stationary seal **8** with O-Ring **9**, making sure that the holes on stationary seal are in position with holes in body and tighten the screws **20** using a threadlock product
- On the rotor **11** mount the first bearing **2** with the closed side facing the thread up to the stop, place the spacer **3**, mount the second bearing **2** with open side facing the first bearing
- Fit the snap ring **4**
- Mount the O-Ring **5** in its rotor seat and lubricate it with silicone grease
- Insert the rotating face seal **6** by placing the notch on the outside diameter is engaged by the anti-rotation pin **13** on rotor
- Wipe with a clean damp cloth with acetone flat the surfaces of the rotating seal **6** and the stationary **8**
- Then insert the rotor **11** in the bearings housing **12** in the vertical direction, applying a slight axial pressure on the rotor until it is brought in such a position as to uncover the circular groove for snap ring **1**
- Install the snap ring **1**
- Mount body **10** with bearings housing **12** using the screws **16**, check tightening torque to be **24,6 Nm**
- Test it before putting i tinto service

REMOVAL AND REPAIR INSTRUCTIONS **GR 65÷80 R**



TABELLA 1 - Operating temperature up to 100°C



TABELLA 1 - Operating temperature up to 150°C

Modello Type	Quantità di grasso per lubrificazione periodica Grease quantity for lubrication interval cm^3
GR-65-R	32
GR-80-R	42
GR-90-R	52
GR-100-R	52

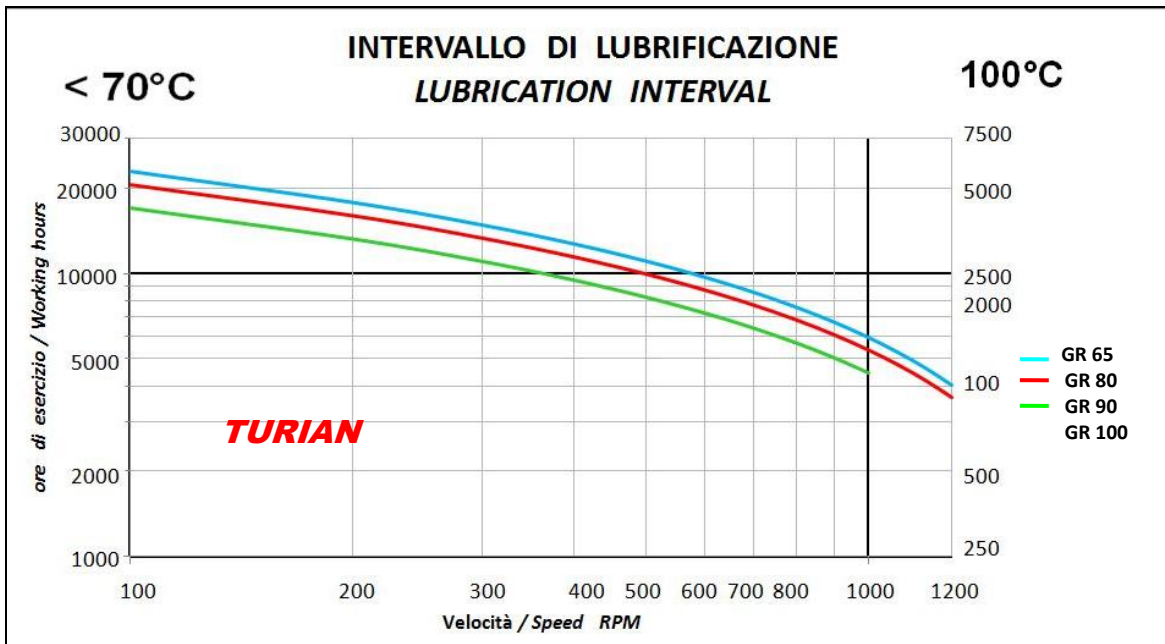
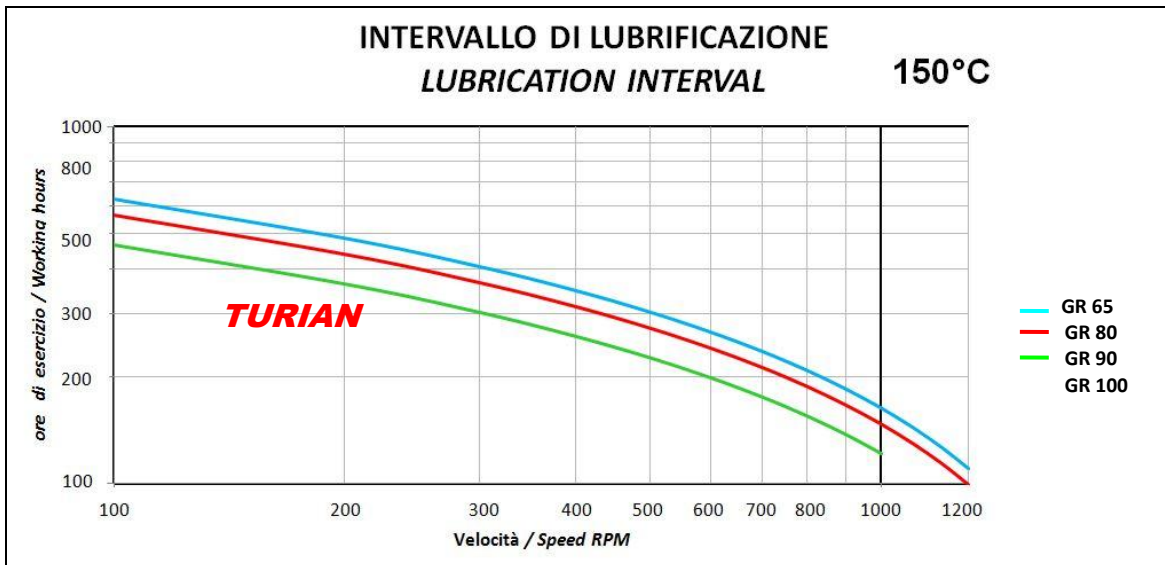
TABELLA 2 - Amount of grease lubricant